

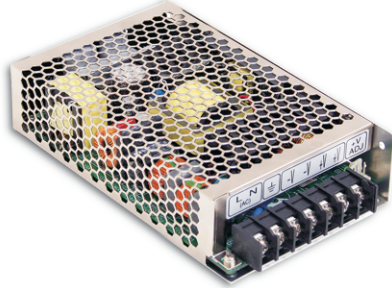

150W Single Output with PFC Function

HRP-150 series



SPECIFICATION

MODEL	HRP-150-3.3	HRP-150-5	HRP-150-7.5	HRP-150-12	HRP-150-15	HRP-150-24	HRP-150-36	HRP-150-48	
OUTPUT	DC VOLTAGE	3.3V	5V	7.5V	12V	15V	24V	36V	48V
	RATED CURRENT	30A	26A	20A	13A	10A	6.5A	4.3A	3.3A
	CURRENT RANGE	0 ~ 30A	0 ~ 26A	0 ~ 20A	0 ~ 13A	0 ~ 10A	0 ~ 6.5A	0 ~ 4.3A	0 ~ 3.3A
	RATED POWER	99W	130W	150W	156W	150W	156W	154.8W	158.4W
	RIPPLE & NOISE (max.) Note.2	80mVp-p	80mVp-p	100mVp-p	120mVp-p	150mVp-p	150mVp-p	200mVp-p	240mVp-p
	VOLTAGE ADJ. RANGE	2.8 ~ 3.8V	4.3 ~ 5.8V	6.8 ~ 9V	10.2 ~ 13.8V	13.5 ~ 18V	21.6 ~ 28.8V	28.8 ~ 39.6V	40.8 ~ 55.2V
	VOLTAGE TOLERANCE Note.3	±2.5%	±2.5%	±2.5%	±1.5%	±1.5%	±1.5%	±1.5%	±1.5%
	LINE REGULATION	±0.5%	±0.5%	±0.5%	±0.3%	±0.3%	±0.2%	±0.2%	±0.2%
	LOAD REGULATION	±1.0%	±1.0%	±1.0%	±0.5%	±0.5%	±0.5%	±0.5%	±0.5%
	SETUP, RISE TIME	1000ms, 50ms/230VAC 2500ms, 50ms/115VAC at full load							
HOLD UP TIME (Typ.)	16ms/230VAC 16ms/115VAC at full load								
INPUT	VOLTAGE RANGE Note.5	85 ~ 264VAC		120 ~ 370VDC					
	FREQUENCY RANGE	47 ~ 63Hz							
	POWER FACTOR (Typ.)	PF>0.95/230VAC		PF>0.99/115VAC at full load					
	EFFICIENCY (Typ.)	80%	85%	87%	88%	88%	88%	89%	89%
	AC CURRENT (Typ.)	2.3A/115VAC		1.3A/230VAC					
	INRUSH CURRENT (Typ.)	35A/115VAC		65A/230VAC					
	LEAKAGE CURRENT	<1mA / 240VAC							
PROTECTION	OVERLOAD	105 ~ 135% rated output power Protection type : Constant current limiting, recovers automatically after fault condition is removed							
	OVER VOLTAGE	3.96 ~ 4.62V	6 ~ 7V	9.4 ~ 10.9V	14.4 ~ 16.8V	18.8 ~ 21.8V	30 ~ 34.8V	41.4 ~ 48.6V	57.6 ~ 67.2V
	OVER TEMPERATURE	95°C (3.3V ~ 7.5V), 85°C (12V ~ 48V) (TSW1 : detect on heatsink Q1 of power transistor) 105°C (3.3V ~ 7.5V), 100°C (12V ~ 48V) (TSW2 : detect on heatsink HS4 of power transistor) Protection type : Shut down o/p voltage, recovers automatically after temperature goes down							
ENVIRONMENT	WORKING TEMP.	-30 ~ +70°C (Refer to output load derating curve)							
	WORKING HUMIDITY	20 ~ 90% RH non-condensing							
	STORAGE TEMP., HUMIDITY	-40 ~ +85°C, 10 ~ 95% RH							
	TEMP. COEFFICIENT	±0.04%/°C (0 ~ 50°C)							
	VIBRATION	10 ~ 500Hz, 5G 10min./1cycle, 60min. each along X, Y, Z axes							
SAFETY & EMC (Note 4)	SAFETY STANDARDS	UL60950-1, TUV EN60950-1 approved							
	WITHSTAND VOLTAGE	I/P-O/P:3KVAC I/P-FG:1.5KVAC O/P-FG:0.5KVAC							
	ISOLATION RESISTANCE	I/P-O/P, I/P-FG, O/P-FG:100M Ohms / 500VDC / 25°C / 70% RH							
	EMI CONDUCTION & RADIATION	Compliance to EN55022 (CISPR22) Class B							
	HARMONIC CURRENT	Compliance to EN61000-3-2,-3							
	EMS IMMUNITY	Compliance to EN61000-4-2,3,4,5,6,8,11; ENV50204, EN55024, EN61000-6-2, heavy industry level, criteria A							
OTHERS	MTBF	238.8K hrs min. MIL-HDBK-217F (25°C)							
	DIMENSION	159*97*38mm (L*W*H)							
	PACKING	0.61Kg; 24pcs/15.6Kg/0.76CUFT							
NOTE	°C								

Mechanical Specification

Case No.901I Unit:mm

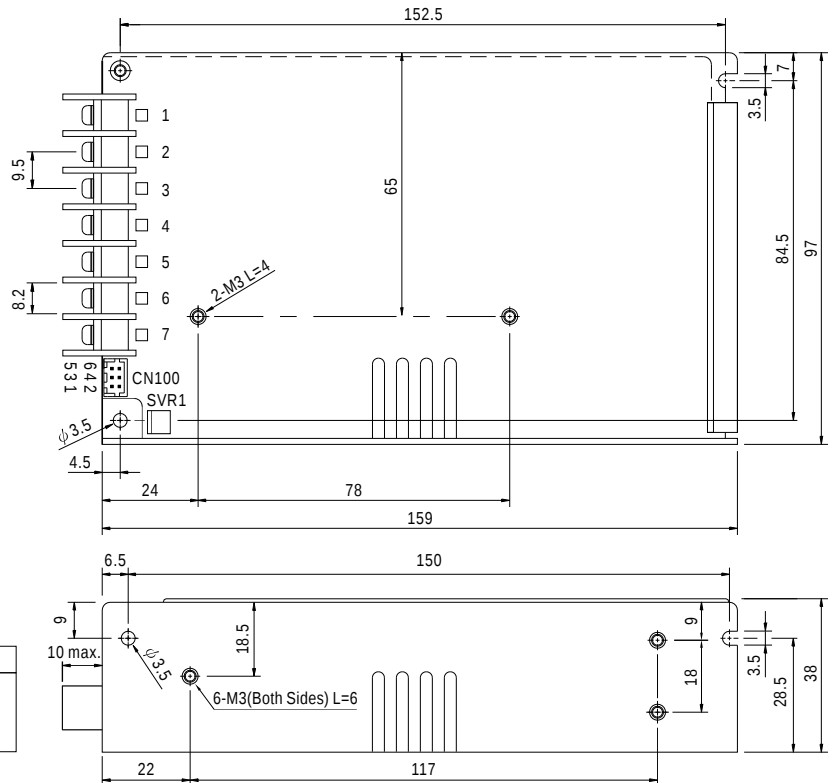

Terminal Pin No. Assignment :

Pin No.	Assignment	Pin No.	Assignment
1	AC/L	4,5	DC OUTPUT -V
2	AC/N	6,7	DC OUTPUT +V
3	FG		

Connector Pin No. Assignment (CN100) :
HRS DF11-6DP-2DS or equivalent

Pin No.	Assignment	Mating Housing	Terminal
1	-S	HRS DF11-6DS or equivalent	HRS DF11-6DS or equivalent
2	+S		
3-6	NC		

Block Diagram

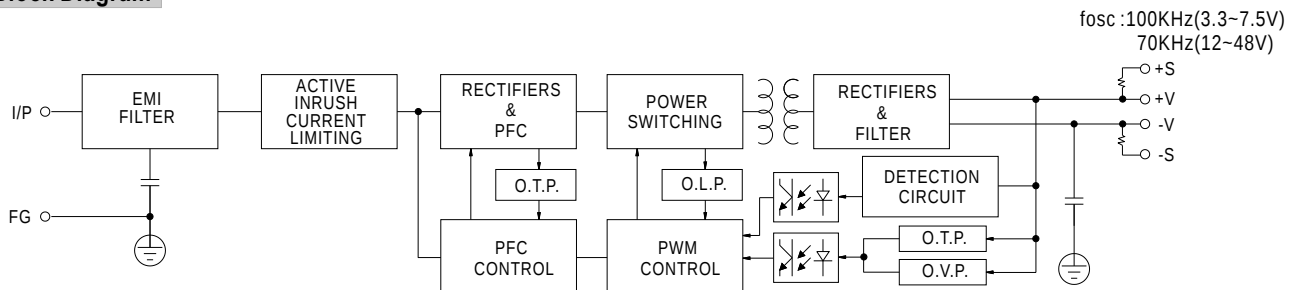

Derating Curve

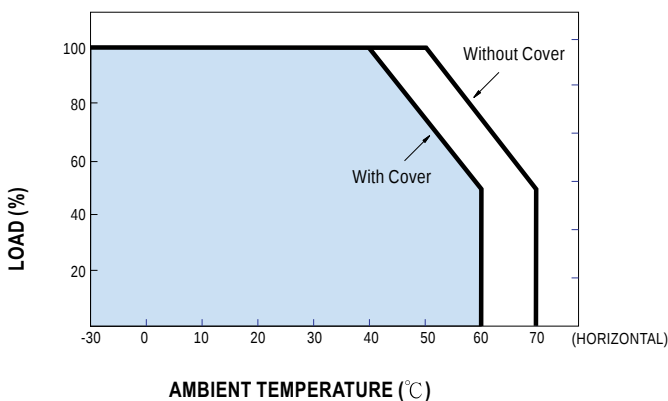

Output Derating VS Input Voltage

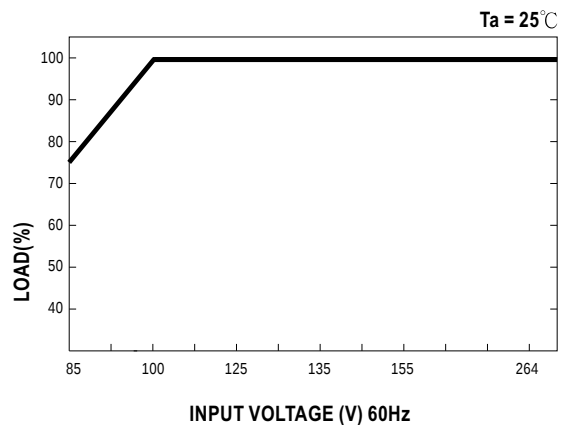

Mechanical Specification

Case No.901I Unit:mm

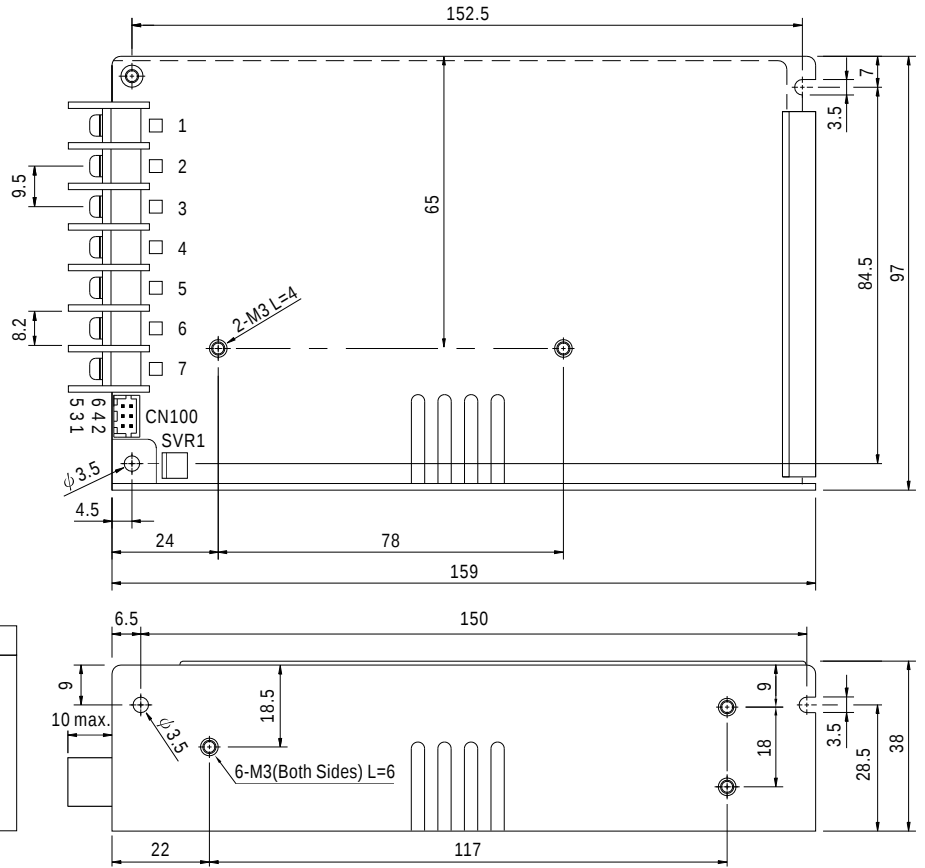

Terminal Pin No. Assignment

Pin No.	Assignment	Pin No.	Assignment
1	AC/L	4,5	DC OUTPUT -V
2	AC/N	6,7	DC OUTPUT +V
3	FG \perp		

Connector Pin No. Assignment (CN100) : HRS DF11-6DP-2DS or equivalent

Pin No.	Assignment	Mating Housing	Terminal
1	-S	HRS DF11-6DS or equivalent	HRS DF11-**SC or equivalent
2	+S		
3	AUXG		
4	AUX		
5	RC-		
6	RC+		

Block Diagram

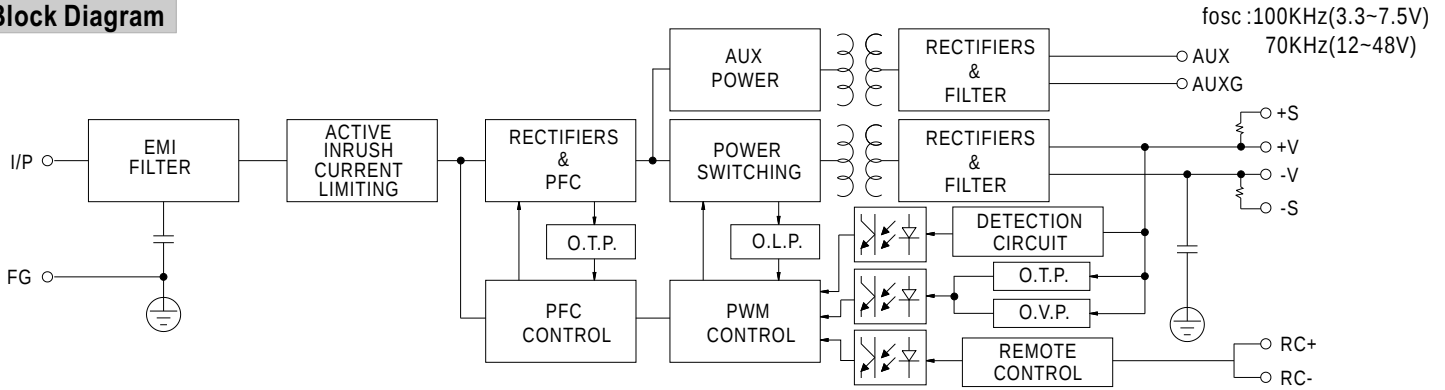

Derating Curve

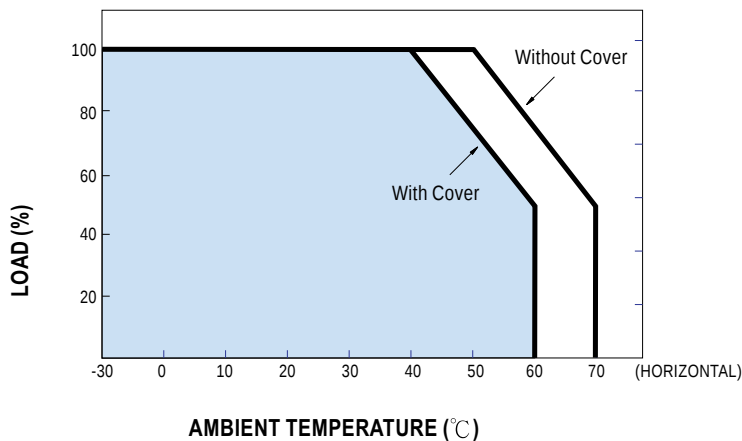

Output Derating VS Input Voltage

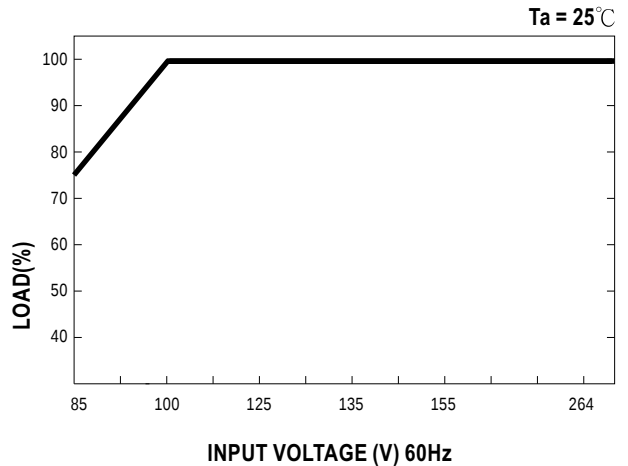

■ Function Description of CN100

Pin No.	Function	Description
1	-S	Negative sensing. The -S signal should be connected to the negative terminal of the load. The -S and +S leads should be twisted in pair to minimize noise pick-up effect. The maximum line drop compensation is 0.5V.
2	+S	Positive sensing. The +S signal should be connected to the positive terminal of the load. The +S and -S leads should be twisted in pair to minimize noise pick-up effect. The maximum line drop compensation is 0.5V.
3	AUXG	Auxiliary voltage output ground. The signal return is isolated from the output terminals (+V & -V).
4	AUX	Auxiliary voltage output, 4.6~5.25V, referenced to pin 3(AUXG). The maximum load current is 0.3A. This output has the built-in oring diodes and is not controlled by the "remote ON/OFF control".
5	-RC	Remote control ground.
6	+RC	Turns the output on and off by electrical or dry contact between pin 5 (RC-). Short: Power OFF, Open: Power ON.

■ Function Manual

1. Remote Control

The PSU can be turned ON/OFF by using the "Remote ON/OFF" function

Between RC-(pin5) and RC+(pin6)	Output Status
SW ON (Short)	OFF
SW OFF (Open)	ON

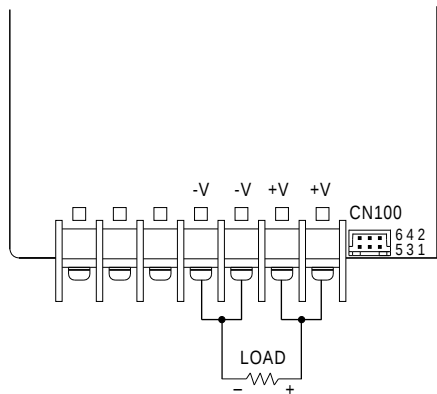
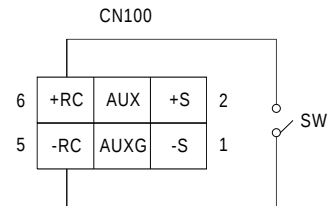

Fig 1.1



2. Remote Sense

The remote sensing compensates voltage drop on the load wiring up to 0.5V.

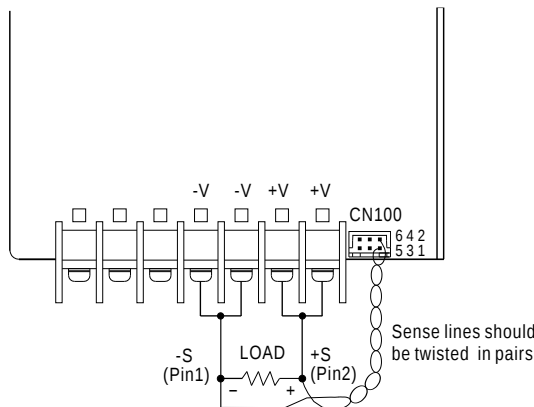

Fig 2.1

